

intersystems

Automatic Filling Systems

9575 N 109th Ave Omaha, NE 68142
402.330.1500 Fax 402.330.3350
www.intersystems.net

MODEL LDS-55

The model LDS-55 is designed to provide accurate, subsurface, liquid dispensing of 55 gallon drums.

Velcon liquid dispensers provide a unique programmable product level tracking system to minimize contamination, reduce drips and maintain a clean lance.

The model LDS-55 has a robust 304 stainless steel structural construction and 316 stainless steel wetted parts. It incorporates an Allen Bradley PLC and HMI based VFC1100 control system. It has built in safety features to guarantee a safe clean and accurate dispensing.

Standard Features

- General purpose Non-Hazardous area electrical classification
- VFC1100 controller Hardware
- Allen Bradley Micrologix PLC with Ethernet IP
- Allen Bradley PanelView-Plus 400 Graphical user interface with Ethernet IP
 - 24V DC controls
 - Software
 - User friendly menu driven system
 - Recipe programming and saving of all set points
 - Resume capability to continue filling aborted cycles
 - Flow rate monitoring
 - Cycle time monitoring
 - System Alarm display plus historian
 - Weight indicator control, Zero, Tare, Gross/Net
 - See VFC1100 controller manual for full standard features
- Air motor and ball screw driven SUB-SURFACE LOWER BY WEIGHT SYSTEM. This system will dispense in subsurface mode keeping the lance at programmable position. Dispensing using this method eliminates contamination and keeps the lance clean.
- Hand operated lever for Start/Stop operation

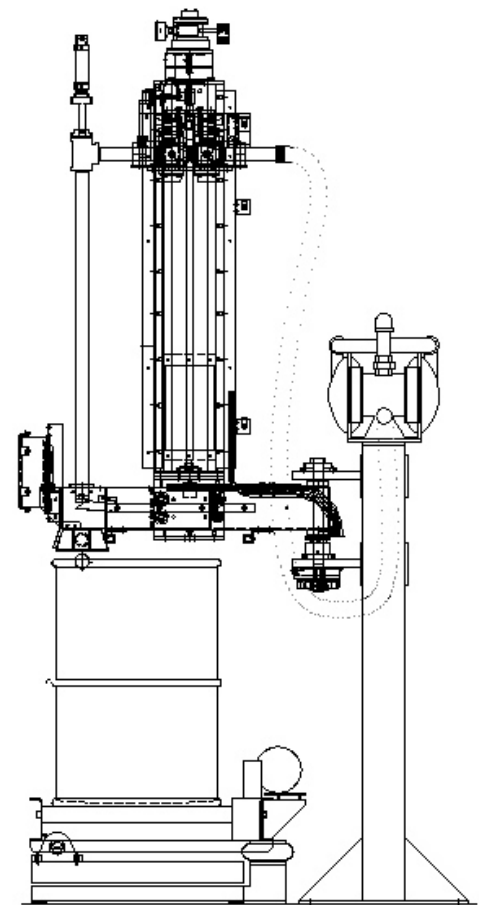

Standard Construction

- 304 stainless steel structural construction
- 316 stainless steel wetted parts (Lance and pipe).
- Powder coated carbon steel control NEMA-4 enclosures
- Two piece 316 stainless steel ball valves
- Foot valve at end of lance for minimizing drips
- Gravity weighed stainless steel drip cup
- Fume collection hood with sight glass and 2" hose connection
- Teflon seals and seats
- Sealed bearings and cam followers
- Carbon steel ball screw drive system
- Carbon steel low profile scale case
 - Raised Platform
 - Sealed load cells
 - 1 part in 5,000 resolution (5,000 Lb X 1.0 LB)
 - 5,000 LB capacity

Available Options

1. Electrical area classification Options
 - Class-I Division-I area package
 - Class-I Division-II area package
2. Controller Options
 - Upgrade to PanelView-Plus 600 Color
3. Environmental area Options
 - Corrosive area package
4. Scale Base Options
 - Stainless steel scale base
 - High Capacity scale base
 - High precision scale base
5. Lance Options
 - Sanitary Lance
 - Corrosive
 - Quick Disconnect
6. Enclosure Options
 - Stainless steel
7. Structural Options
 - Adjustable Stanchion (Tote Option)
 - Dual Lance
 - Hinged wiper ring housing
 - Long Stroke Lance
8. Pneumatic Drip-pan
9. Purge through lance rod
10. Container grounding and monitoring
11. Accessories
 - Bung tooling
 - Work platform
 - Scale mount
 - Line voltage regulator
 - Step-down transformer
 - Serial Printer
 - Spare parts
12. Conveyor
 - Complete Conveyor line available to complete your System

Sequence of Operation

- Operator programs VFC1100 for dispense presets in program mode and switches to run mode
- System is ready for a dispense cycle and displays “Ready To Dispense”.
- Operator moves the drum onto the scale.
- Using the swing arm brake release and visual alignment aid, the lance is centered over a bung opening.
- The Operator pulls down the Start lever
- Controller checks for presence of container on scale. If container is not detected (this is accomplished by checking the weight on the scale) the cycle is aborted automatically (Start Lever is automatically kicked up) and an error message is displayed on the PanelView plus screen.
- The lance is lowered to the product level, monitoring for lance misalignment.
- System opens the foot valve and ball valves
- System starts the dispense cycle.
- System dispenses until target weight is met or container is emptied.
- The lance will lower by weight tracking the product level during the entire dispense cycle.
- Once the bottom of the drum is detected, the lance will raise slightly. The scale will tilt and the lance lowers again, dispensing the remainder of the product.
- System closes the foot valve and ball valve.
- System starts raising the lance to the top position.
- System kicks the Start lever up.
- System sends dispense data through the serial port on the PanelView Plus.
- System is ready to dispense next container.